



# USER'S MANUAL RD-SI02

## SOLDERING IRON

Dear Customer,

Congratulations on the purchase of machinery from the fastest growing brand of electric and pneumatic tools - RAIDER. When properly installed and operating, RAIDER are safe and reliable machines and work with them will deliver a real pleasure. For your convenience has been built and excellent service network of 32 service station across the country.

Before using this machine, please carefully acquainted with these "instructions for use". In the interest of your safety and to ensure proper use and read these instructions carefully, including the recommendations and warnings in them. To avoid unnecessary errors and accidents, it is important that these instructions will remain available for future reference to all who will use the machine. If you sell it to a new owner "Instructions for Use" must be submitted along with it to enable new users to become familiar with relevant safety and operating instructions.

Euromaster Import Export Ltd. is an authorized representative of the manufacturer and owner of the trademark RAIDER.  
Address: Sofia City 1231, Bulgaria "Lomsko shausse" Blvd. 246, tel 02 934 33 33, 934 10 10, www.raider.bg; www.euromasterbg.com; e-mail: info@euromasterbg.com.  
Since 2006 the company introduced the system of quality management ISO 9001:2008 with scope of certification: Trade, import, export and servicing of hobby and professional electrical, mechanical and pneumatic tools and general hardware. The certificate was issued by Moody International Certification Ltd, England.

### TECHNICAL DATA

parameter	unit	value
Model	-	RD-SI02
Voltage	V	220-240
Frequency	Hz	50
Input Power	W	60
Protection class	-	I



**Warning!**  
Read all instructions. Failure to follow all instructions listed below may result in electric shock, fire and/or serious injury. The term "power tool" in all of the warnings listed below refers to your mains operated (corded) power tool or battery operated (cordless) power tool. Save these instructions.

- 1) Work area
- Keep work area clean and well lit. Cluttered and dark areas invite accidents.
  - Do not operate power tools in explosive atmospheres, such as in the presence of flammable liquids, gases or dust. Power tools create sparks which may ignite the dust of fumes.
  - Keep children and bystanders away while operating a power tool. Distractions can cause you to lose control.

- 2) Electrical safety
- Power tool plugs must match the outlet. Never modify the plug in any way. Do not use any adapter plugs which earthed (grounded) power tools. Unmodified plugs and matching outlets will reduce risk of electric shock.
  - Avoid body contact with earthed or grounded surfaces such as pipes, radiators, ranges and refrigerators. There is an increased risk of electric shock if your body is earthed or grounded.
  - Do not expose power tools to rain or wet conditions. Water entering a power tool will increase the risk of electric shock.
  - Do not abuse the cord. Never use the cord for carrying, pulling or unplugging the power tool. Keep cord away from heat, oil, sharp edges or moving parts. Damaged or entangled cords increase the risk of electric shock.
  - When operating a power tool outdoors, use an extension cord suitable for outdoor use. Use of a cord suitable for outdoor use reduces the risk of electric shock. Always use tool in conjunction with a residual circuit breaker device.

- 3) Personal safety
- Stay alert, watch what you are doing and use common sense when operating a power tool. Do not use a power tool while you are tired or under the influence of drugs, alcohol or medication. A moment of inattention while operating power tools may result in serious personal injury.
  - Use safety equipment. Always wear eye protection. Safety equipment such as dust mask, non-skid safety shoes, hard hat, or hearing protection used for appropriate conditions will reduce personal injuries.
  - Avoid accidental starting. Ensure the switch is in the off position before plugging in. Carrying power tools with your finger on the switch or plugging in power tools that have the switch on invites accidents.
  - Remove any adjusting key or wrench before turning the power tool on. A wrench or a key left attached to a rotating part of the power tool may result in personal injury.
  - Do not overreach. Keep proper footing and balance at all times. This enables better control of the power tool in unexpected situations.
  - Dress properly. Do not wear loose clothing or jewellery. Keep your hair, clothing and gloves away from moving parts. Loose clothes, jewellery or long hair can be caught in moving parts.
  - If devices are provided for the connection of dust extraction and collection facilities, ensure these are connected and properly used. Use of these devices can reduce dust related hazards.

- 4) Power tool use and care
- Do not force the power tool. Use the correct power tool for your application. The correct power tool will do the job better and safer at the rate for which it was designed.
  - Do not use the power tool if the switch does not turn it on and off. Any power tool that cannot be controlled with the switch is dangerous and must be repaired.
  - Disconnect the plug from the power source and /or the battery pack from the power tool before making any adjustments, changing accessories, or storing power tools. Such preventive safety measures reduce the risk of starting the power tool accidentally.
  - Store idle power tools out of the reach of children and do not allow persons unfamiliar with the power tool or these instructions to operate the power tool. Power tools are dangerous in the hands of untrained users.
  - Use the power tool, accessories and tool bits etc. in accordance with these instructions and in the manner intended for the particular type of power tool, taking into account the working conditions and the work to be performed. Use of the power tool for operations different from those intended could result in a hazardous situation.
- 5) Service
- Have your power tool serviced by a qualified repair person using only identical replacement parts. This will ensure that the safety of the power tool is maintained.
  - Caution! The use of any accessories or additional tools other than those recommended in this manual may lead to an increased risk of injury. Only use original replacement parts.

### OPERATING

- Connect the plug to an outlet.
- Put the soldering iron on the stand, until soldering tip is well heated.
- Melt some soldering tin on the soldering tip.
- Put the soldering tip to the point to be soldered.
- Send some soldering tin to the point, until soldering tin melt.
- Melt some tin to the other soldering part.
- Solder the two parts together; avoid over heated, cool the soldering point.



The machine, accessories and packaging should be sorted for environmental-friendly recycling. The plastic components are labelled for categorized recycling. Do not dispose of power tools into household waste! According the European Guideline 2012/19/EC for Waste Electrical and Electronic Equipment and its Implementation into national right, power tools that are no longer usable must be collected separately and disposed of in an environmentally correct manner.



### EU DECLARATION OF CONFORMITY

Euromaster Import Export Ltd.  
Address: Sofia 1231, Bulgaria, 246 Lomsko shausse Blvd.

Product: Soldering Iron  
Trademark: RAIDER  
Model: RD-SI02

is designed and manufactured in conformity with following Directives:

2014/30/EU of the european parliament and of the council of 26 February 2014 on the harmonisation of the laws of the Member States relating to electromagnetic compatibility

2014/35/EU of the European Parliament and of the Council of 26 February 2014 on the harmonisation of the laws of the Member States relating to the making available on the market of electrical equipment designed for use within certain voltage limits

and fulfils requirements of the following standards:

EN 60335-1:2012+A11:2014  
EN 60335-2-45:2002+A1:2008+A2:2012  
EN 61000-3-2:2014  
EN 61000-3-3:2013  
EN 61000-6-1:2007  
EN 61000-6-3:2007+A1:2011+AC:2012



Place&Date of Issue:  
Sofia, Bulgaria  
December 20, 2019

Brand Manager: *Krasimir Petkov*  
Krasimir Petkov

### Explode Drawing of RD-SI02 Soldering Iron

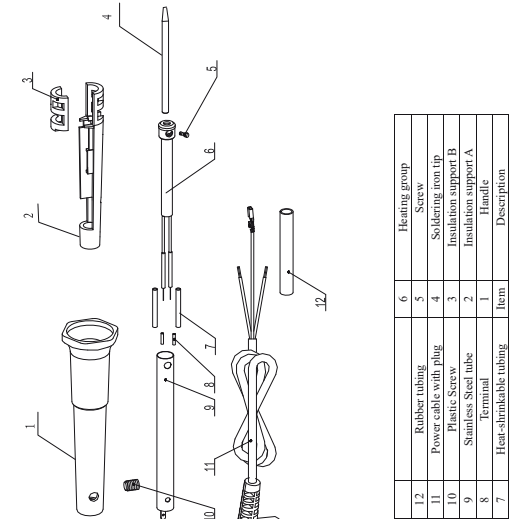

## RAIDER® WARRANTY CARD

MODEL.....

SERIAL № .....

TERM .....

(for details see the warranty conditions)

№, date of invoice / cash receipt.....

**DETAILS OF BUYER**

NAME / COMPANY .....

(be filled in by the employee)

ADDRESS.....

(be filled in by the employee)

SIGNATURE OF BUYER.....

(I am familiar with warranty conditions and the operating device is in good working order and accessory)

**DETAILS OF SELLER**

NAME / COMPANY .....

(be filled in by the employee)

ADDRESS.....

(be filled in by the employee)

DATE / STAMP .....

SERVICE REPORT				
Receiving Protocol	Date of adoption	Description of the defect	Date of transmission	Signature

Central Service: Bulgaria, Sofia, "Lomsko shose" 246, tel.: +359 700 44 155 (free for the whole country).